

# KOHLER® Courage®

15-27 hp Engines



**KOHLER®**

## KOHLER® Courage – Professional-grade engineering for the consumer.

Today, more and more consumers are demanding professional-grade products. Products that deliver power, performance and convenience. And KOHLER Courage® gives it to them. Introducing the first KOHLER engine designed specifically for consumer applications, Courage delivers more displacement, across the board, for more power. Easier starts, reduced noise, vibration, emissions and fuel consumption – and easy maintenance. It's what professionals have come to expect from Kohler and what today's informed consumer market demands.

### Overhead Valve.

Engines featuring an overhead valve (OHV) design deliver smoother running, more fuel efficient performance. Because of the increased volumetric efficiency, an OHV engine will produce more torque per unit of displacement than a side valve engine. The life of an OHV engine is also longer because the design allows greater airflow around the cylinder head keeping the engine cooler and reducing oil consumption.

### Cast Iron Liners.

Further extending engine life, cast iron liners provide added protection under extreme load and dirty operating conditions.

### Full Pressure Lubrication.

Full pressure lubrication is standard on all Kohler Courage engines. Oil is distributed continuously, and a full-flow oil filter protects critical rotating parts for longer engine life. The high-efficiency Gerotor™ oil pump ensures lubrication to critical components.

# KOHLER®

PERFORMANCE  
ENGINEERING

Every part, every component, every system on our engines is guided by Kohler's exclusive Performance Engineering. It's your assurance that every engine we produce will live up to and build upon the worldwide KOHLER® reputation for excellence.





# KOHLER® Courage Singles

The engine that's taking the consumer lawn and garden market by storm. The KOHLER Courage® single-cylinder engine delivers more horsepower and greater displacement than any engine in its class. With patented features like a crossflow cylinder head, a dual-reciprocating balance valve, an inverted crankcase and a vtwin-cam design, Courage gives consumers the power and response that makes KOHLER the brand of choice for professionals.

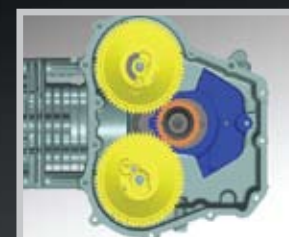

### Twin-Cam Design\*

Delivers responsive power and opens the cylinder head for superior cooling, resulting in longer life and reliability.



### Dual-Reciprocating Balance System\*

An advanced KOHLER balance system provides smooth, comfortable operation.

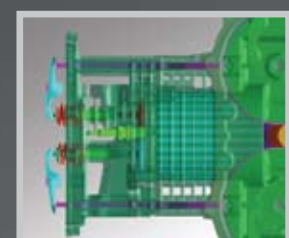

### Crossflow Cylinder Head\*

The twin cam separates the valve assembly, opening up the head for greater airflow and a cooler running engine. A cooler engine – with less bore distortion – offers lower oil consumption, longer life and more useable power.



### Inverted Crankcase\*

This unique configuration ensures leakproof operation.

### Emissions:

Certified for both EPA and California emissions standards. Precise air-to-fuel ratio for cleaner combustion with optimum horsepower and torque.

### Service:

Backed by more than 13,000 dealers and distributors worldwide.

### Warranty:

Two-year limited warranty covering all consumer and commercial applications.

## 15-22 hp vertical-shaft engines

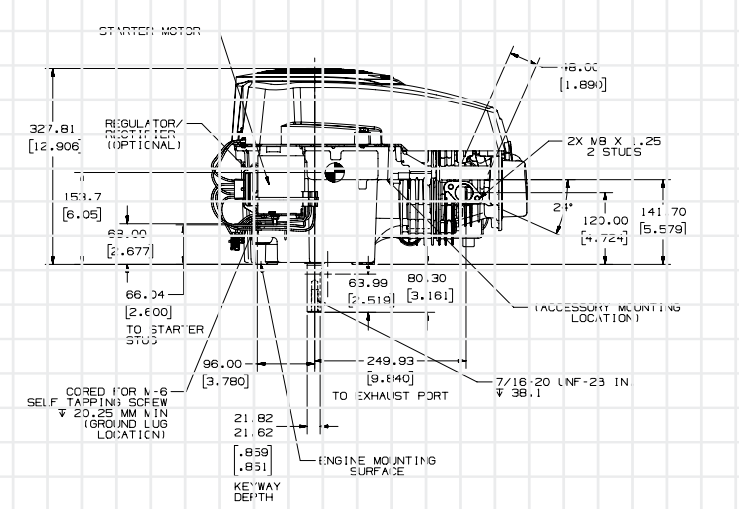
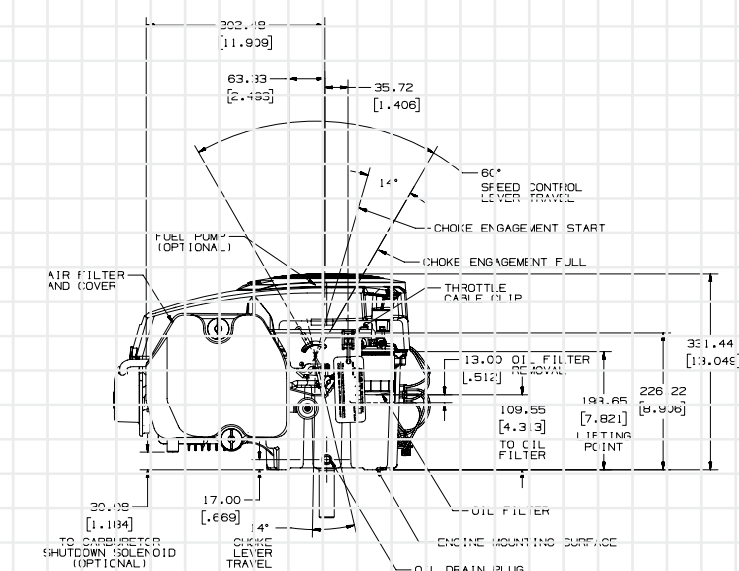
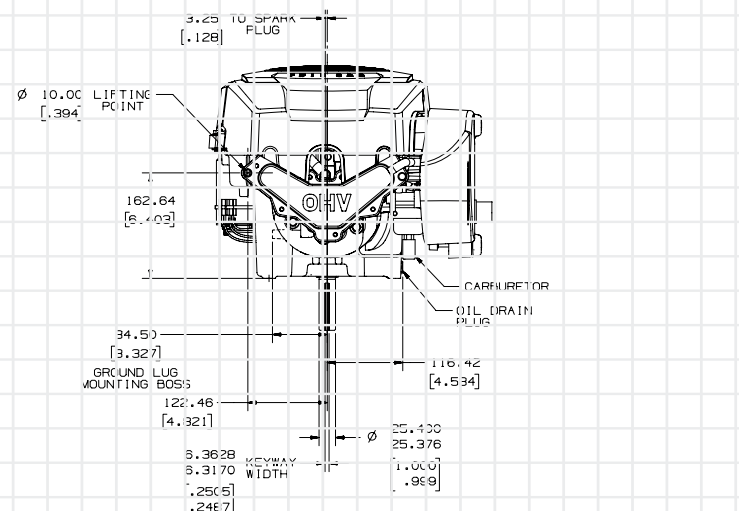

## 15-22 hp vertical-shaft engines

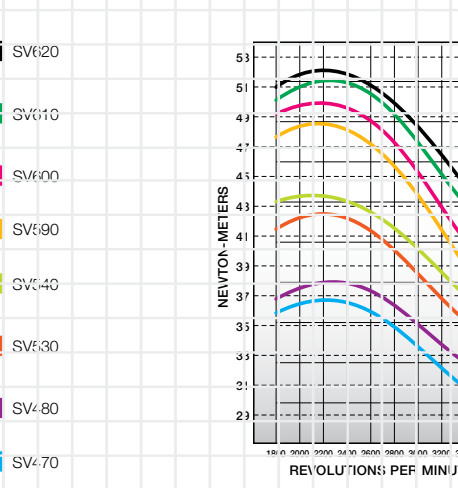
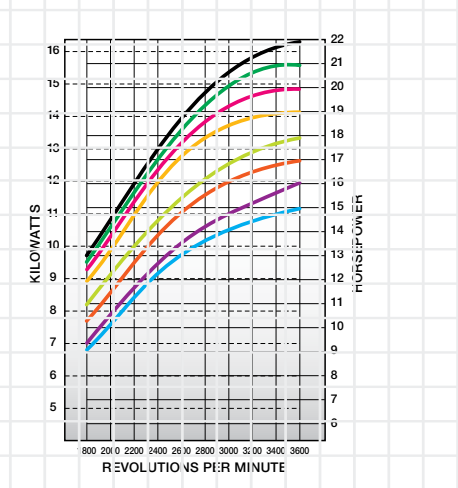
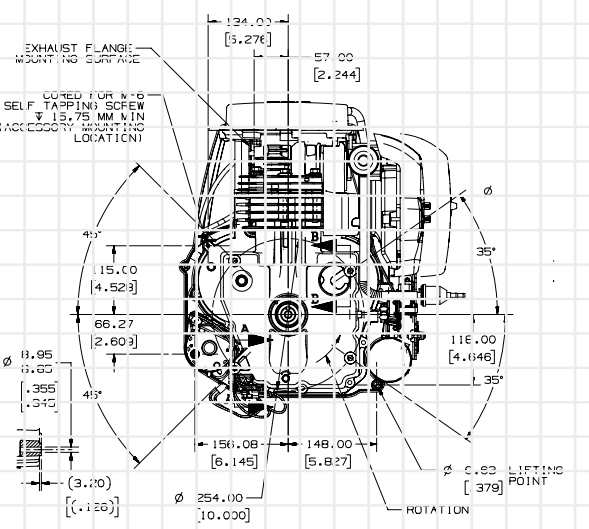
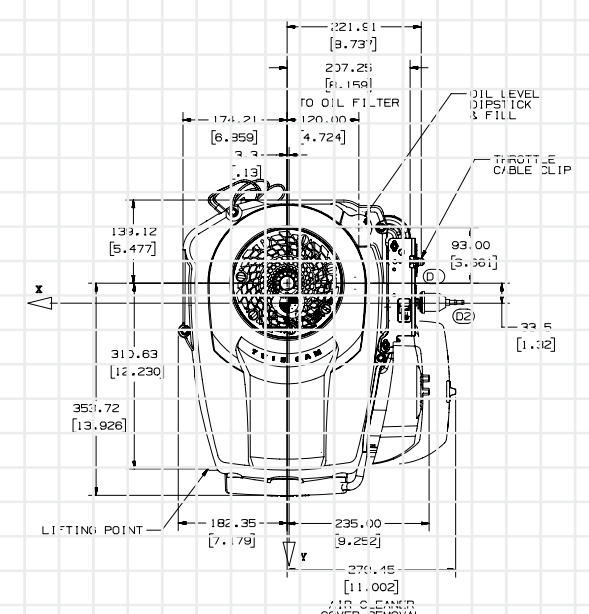

Engines that set the standard.





## KOHLER® Courage Twins

KOHLER – the power more professionals demand – delivers even more power for the consumer lawn and garden market. The KOHLER Courage® twin-cylinder, vertical-shaft, OHV engines from 20 to 27 hp. Power. Performance. Convenience. Just what you expect from Kohler.



### Modulated cooling fan.

Delivers responsive power and opens the cylinder head for superior cooling, resulting in longer life and reliability.



### High-torque inertia drive starter.

Start easy. Finish faster. KOHLER Courage twins make quick work of the most demanding tasks.



### Top-mount air filter.

Easy-access air filter allows for quick inspection and changes.



### Easy oil fill.

The oil fill and dipstick are designed with an extra wide opening for fast, no mess oil fills.

KOHLER® COURAGE® ENGINE ARCHITECTURE

## 20-27 hp vertical-shaft engines

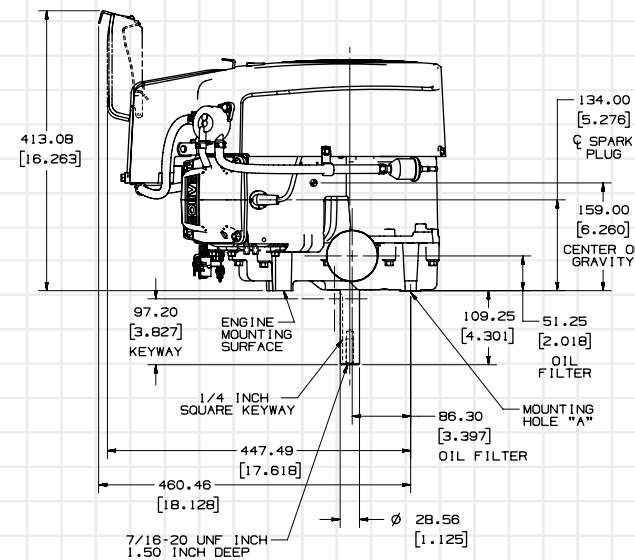
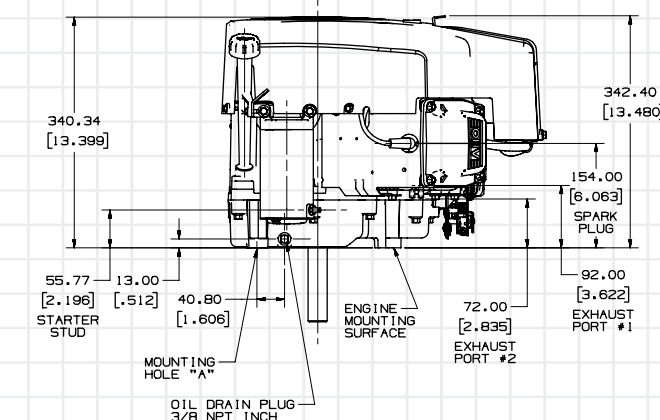
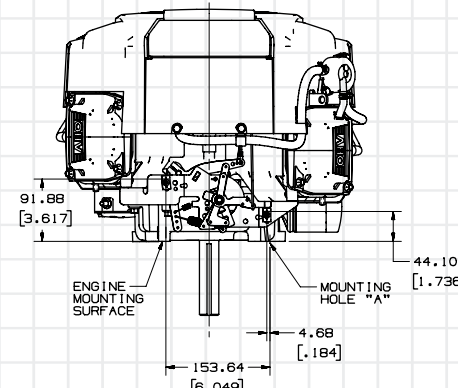

VALVE COVER VIEW

TOP VIEW

STARTER SIDE VIEW

PTO VIEW

OIL FILTER VIEW

## 20-27 hp vertical-shaft engines

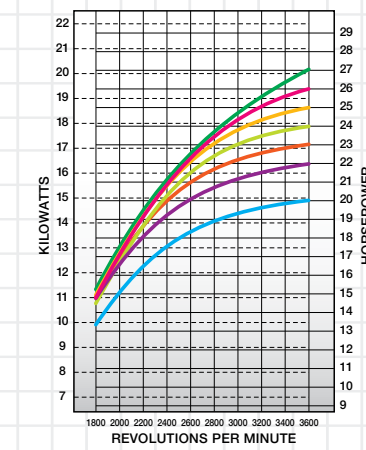
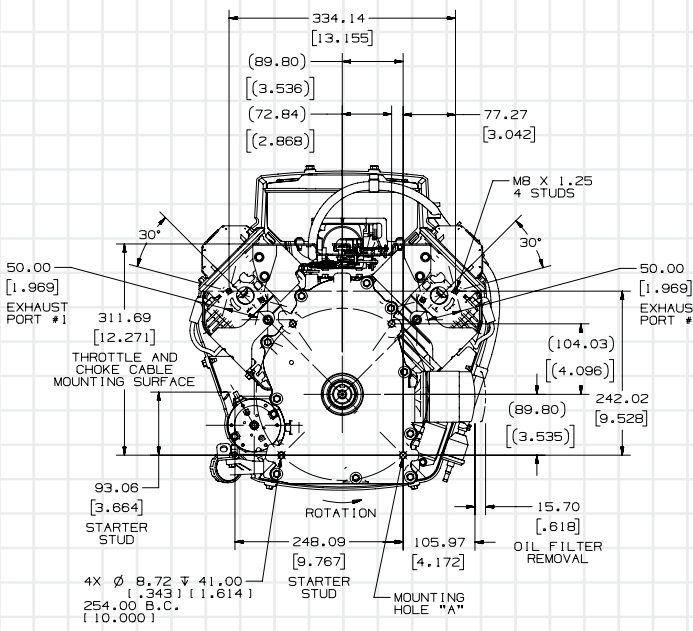
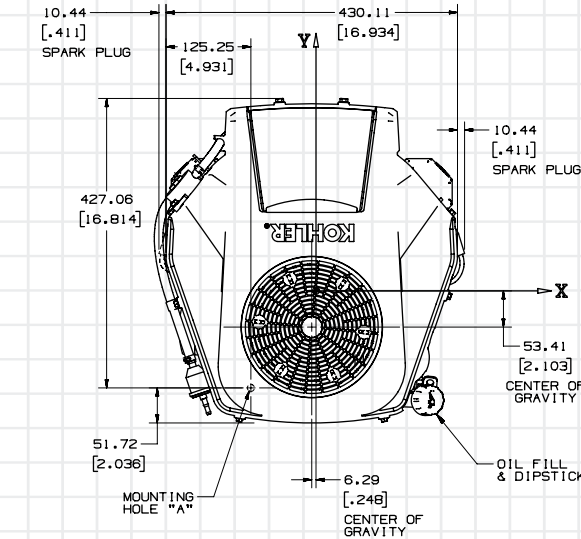

MAXIMUM POWER

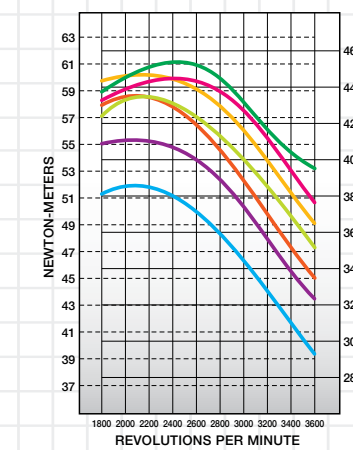

MAXIMUM TORQUE

The performance advantage gets bigger.



## KOHLER® Courage Single-Cylinder Model Specifications

Engine Type		Four-cycle, single-cylinder, air-cooled, vertical-shaft, gasoline, full-pressure lubrication with full-flow filter, aluminum head and crankcase with cast iron cylinder liner.							
Model		SV470	SV480	SV530	SV540	SV590	SV600	SV610	SV620
*Power @ 3600 rpm	Maximum hp (kW)	15 (11.2)	16 (11.9)	17 (12.7)	18 (13.4)	19 (14.2)	20 (14.9)	21 (15.7)	22 (16.4)
Displacement	cu in (cc)	32.6 (535)				36.4 (597)			
Bore	in (mm)	3.5 (89)				3.7 (94)			
Stroke	in (mm)	3.4 (86)							
Peak Torque @ Maximum	ft lb	27(36.6) @ 2200 rpm	27.9 (37.8) @ 2200 rpm	31.5 (42.7) @ 2200 rpm	32.1 (43.5) @ 2200 rpm	36 (48.8) @ 2200 rpm	36.9 (50.0) @ 2200 rpm	38.1 (51.6) @ 2200 rpm	38.8 (52.6) @ 2200 rpm
Compression Ratio		9.4:1				8.5:1			
Dry Weight	lb (kg)	79 (35.8)							
Oil Capacity w/Filters	U.S. qt (L)	1.6 (1.5)							
Lubrication		Full-pressure lubrication with full-flow filter							
**Dimensions L x W x H	in (mm)	19.4 x 16.4 x 12.9 (493 x 417 x 328)							

## KOHLER Courage® Twin-Cylinder Model Specifications

Engine Type		Four-cycle, twin-cylinder, air-cooled, vertical-shaft, gasoline, pressure lubrication with full-flow filter, aluminum head and crankcase with cast iron cylinder liner.						
Model		SV710	SV715	SV720	SV725	SV730	SV735	SV740
*Power @ 3600 RPM	Maximum hp (kW)	20 (14.9)	22 (16.4)	23 (17.2)	24 (17.9)	25 (18.6)	26 (19.4)	27 (20.1)
Displacement	cu in (cc)	44 (725)						
Bore	in (mm)	3.3 (83)						
Stroke	in (mm)	2.6 (67)						
Peak Torque @ Maximum	ft lb (Nm)	38.4 (52.0) @ 2200 rpm	41.0 (55.6) @ 2200 rpm	43.5 (59.0) @ 2200 rpm	43.3 (58.7) @ 2200 rpm	44.8 (60.7) @ 2200 rpm	44.4 (60.2) @ 2400 rpm	45.4 (61.5) @ 2400 rpm
Compression Ratio		9:1						
Dry Weight	lb (kg)	91 (41.3)						
Oil Capacity w/Filters	U.S. qt (L)	2 (1.9)						
Lubrication		Pressure lubrication with full-flow filter						
***Dimensions L x W x H	in (mm)	18.5 x 17.8 x 13.4 (471 x 451 x 340)						

Preliminary info, subject to change.

\*Horsepower ratings exceed Society of Automotive Engineers Small Engine Test Code J1940. Actual engine horsepower is lower and affected by, but not limited to, accessories (air cleaner, exhaust, charging, cooling, fuel pump, etc.), application, engine speed and ambient operating conditions (temperature, humidity and altitude). For more information, contact Kohler Co. Engine Engineering.

Kohler reserves the right to change product specifications, designs and equipment without notice and without incurring obligation.

\*\*Length is valve cover to end of blower housing. Width is air cleaner to opposite side. Height is mounting surface to grass screen.

\*\*\*Length is front of air cleaner cover to end of blower housing. Width is side to side. Height is mounting surface to grass screen.



For more information, contact your KOHLER source of supply  
Or call toll-free in the U.S. and Canada 1-800-544-2444.

Kohler Co., Kohler, Wisconsin 53044 Tel 920-457-4441 Fax 920-459-1570

[KohlerEngines.com](http://KohlerEngines.com)

© 2007 by Kohler Co. All rights reserved.

**KOHLER®**

Relentless Power.  
Legendary Performance.

Printed in U.S.A. E-2122-A 10/07