

KOHLER® Courage®

6.5 hp Engines



KOHLER.

KOHLER®

PERFORMANCE
ENGINEERING

Every part, every component, every system on a KOHLER® engine is guided by our exclusive Performance Engineering standards — standards that drive us to operate on the leading edge of innovation, to push the boundaries of cleaner, more efficient engines, and to manufacture the highest performing, most reliable engines on the market. That's Performance Engineering.



Designed specifically for consumer applications, the Courage® family of engines feature steel-forged crankshafts, advanced ignition systems and provide greater displacement for greater power. You'll also get dual ball bearings for easy starts, reduced noise, vibration, emissions and better fuel efficiency.



Professional Grade Features for the Consumer.

Overhead valve for better fuel efficiency and cleaner emissions, cast iron cylinder bore and steel forged crankshaft provide added protection under load, extending the engine life.



Superior Startability.

The large indexable recoil starter and dual ball bearings make starting the engine nearly effortless.



Easy to Use and Maintain.

No matter the application, the dual oil fills and drains provide the user accessibility to fill and drain the oil from either side of the engine. Along with the large metal fuel tank, easy access controls and no tools required air cleaner, this engine top's the easy-to-use category.



Designed for Dependability.

Standard features like our Oil Sentry™ low-oil protection system and dual fuel filters – in both the fill neck and in the tank – enhance the lifespan of the engine.

Emissions:

Certified for both EPA and California emissions standards. Precise air-to-fuel ratio for cleaner combustion with optimum horsepower and torque.

Service:

Backed by more than 13,000 dealers and distributors worldwide.

Warranty:

Two-year limited warranty covering all consumer applications.



6.5 hp engines (SH265)

KOHLER® COURAGE® ENGINE ARCHITECTURE

TOP VIEW

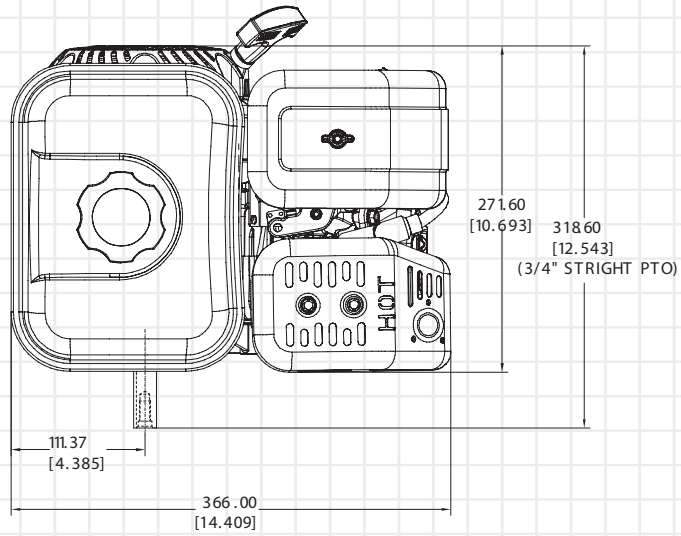

PTO VIEW

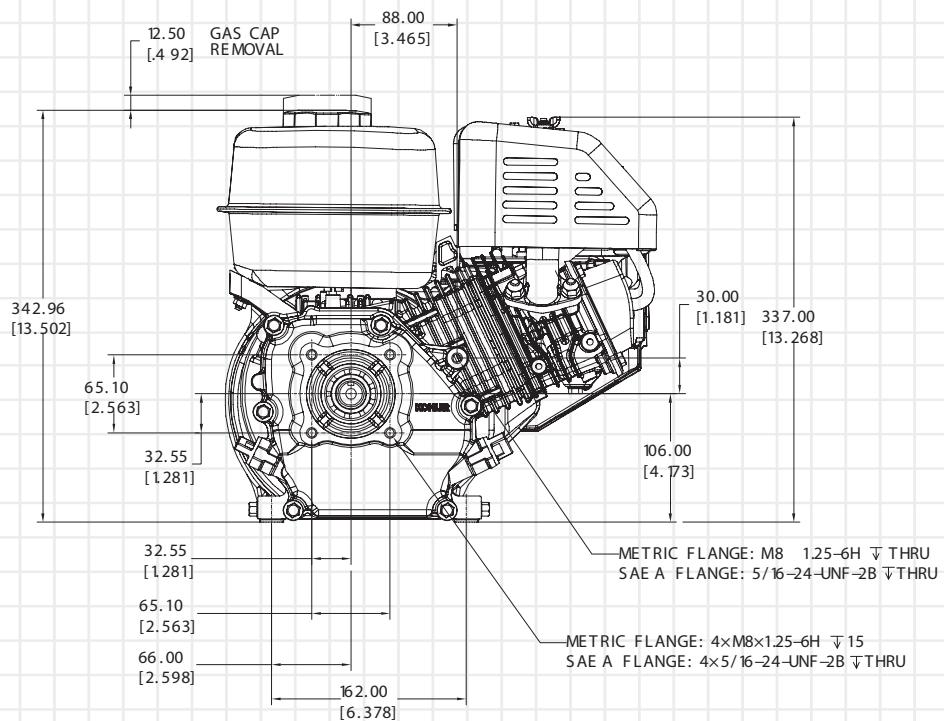

6.5 hp engines (SH265)

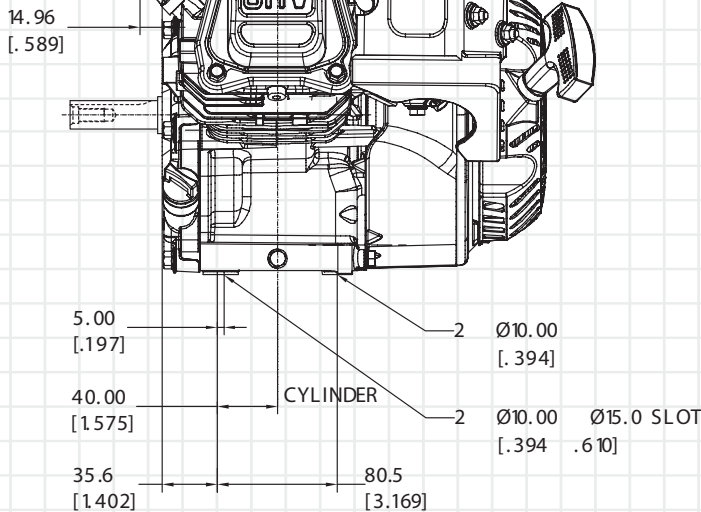
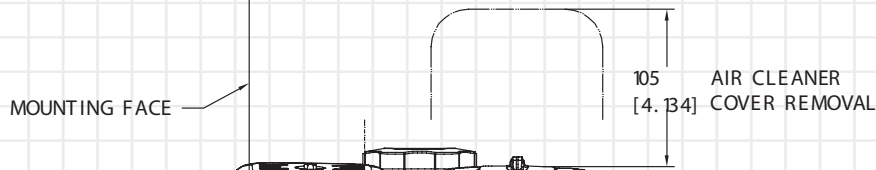
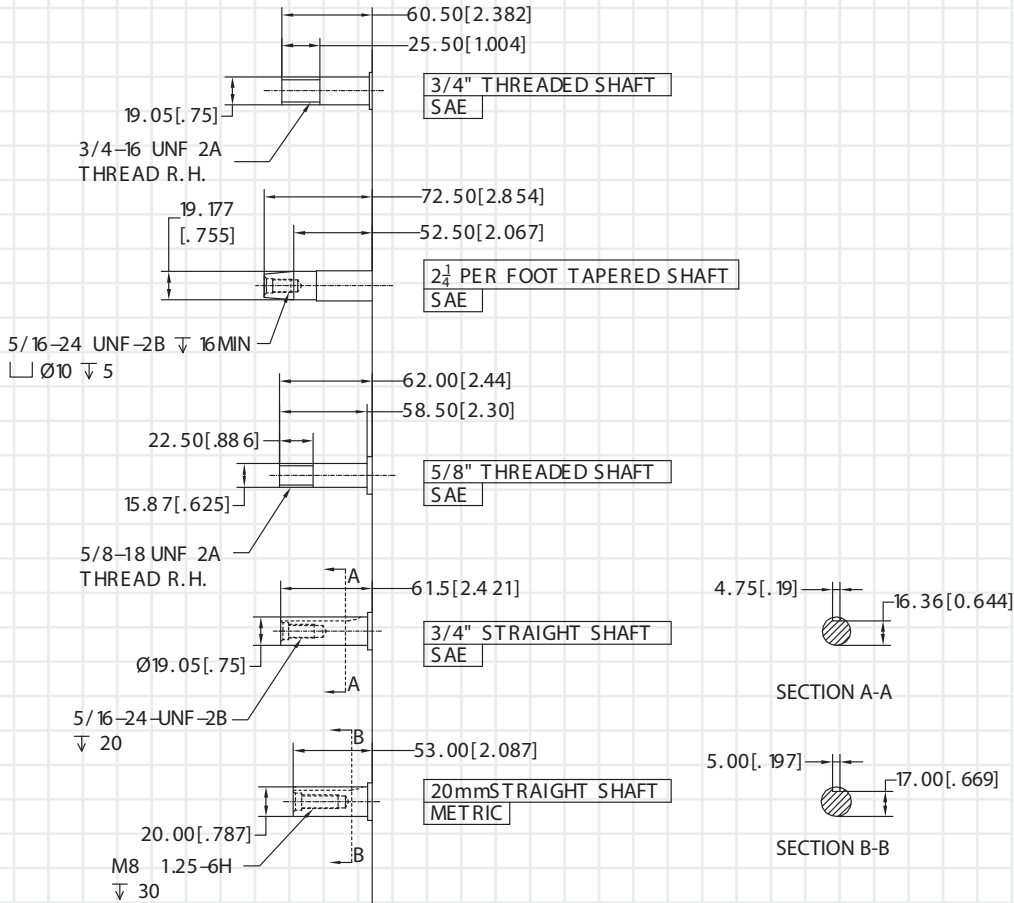

SHAFT VARIATIONS

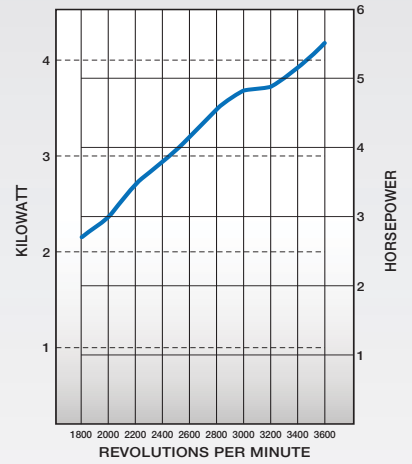

Net Power

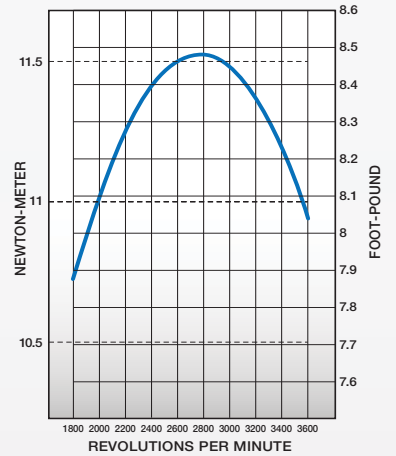

Net Torque

SIDE VIEW



KOHLER® Courage® Model Specifications

Engine Type	Four-cycle, single cylinder, slant cylinder, overhead valve, air-cooled, gasoline, horizontal shaft, aluminum head and crankcase with cast iron cylinder liner.	
Model:	SH265	
*Gross Power @ 3600 rpm	Maximum hp (kW)	6.5 (4.9)
*Net Power @ 3600 rpm	Maximum hp (kW)	5.5 (4.1)
Displacement	cu in (cc)	12 (196)
Bore	in (mm)	2.7 (68)
Stroke	in (mm)	(2.1) 54
Net Peak Torque @ rpm	lbs ft (Nm)	8.5 (11.5) @ 2800
Compression Ratio		8.5:1
Dry Weight (Recoil Start)	lbs (kg)	35.3 (16)
Oil Capacity	U.S. qt (L)	.63 (.6)
Fuel Capacity	U.S. qt (L)	3.8 (3.6)
Lubrication		Splash
**Dimensions L x W x H	in (mm)	12.3 x 14.3 x 13.5 (313 x 363 x 342)

* Horsepower ratings exceed Society of Automotive Engineers Small Engine Test Code J1940. Actual engine horsepower is lower and affected by, but not limited to, accessories (air cleaner, exhaust, charging, cooling, fuel pump, etc.), application, engine speed and ambient operating conditions (temperature, humidity and altitude). For more information, contact Kohler Co. Engine Engineering. Kohler reserves the right to change product specifications, designs and equipment without notice and without incurring obligation.

** Measurements based off a base engine without electric start.

Standard Features

- OHV slant cylinder
- Cast iron cylinder liner
- Large capacity metal fuel tank
- Metal fuel cap
- In-neck fuel debris screen
- Water trap in carburetor
- Electronic ignition
- Quiet muffler with heat shield
- EPA and European emission certified
- Easy access throttle, choke and fuel shut-off
- Automatic compression release
- Mechanical governor
- Sound-deadening alloy crankcase
- Dual ball bearings
- Steel forged and hardened crankshaft
- Carburetor bowl drain
- Dual oil fills and drains
- Oil Sentry™ - automatic low oil shutdown system
- Dual-element air cleaner
- High inertia flywheel
- Silenced air intake
- Indexable easy-pull recoil starter

Popular Factory Options

- 12-volt starter
- Exhaust deflector
- Spark arrestor
- 3- and 10-amp
- Crankshaft/PTO variations (Keyed, Tapered, Threaded)
- Remote throttle
- EMC/RFI Compliant
- Low-profile air cleaner and muffler (Generator)
- Carb Tier III compliant
- EU emission and noise compliant



For more information, contact your KOHLER source of supply
Or call toll-free in the U.S. and Canada 1-800-544-2444.

Kohler Co., Kohler, Wisconsin 53044 Tel 920-457-4441 Fax 920-459-1570

KohlerEngines.com

© 2009 by Kohler Co. All rights reserved.

KOHLER®

Relentless Power.
Legendary Performance.

Printed in U.S.A. E-2143 5/09